

# TIME MACHINE

COMING SOON



**THEO**  
**TM-300**  
**HANDHELD**  
**LASER**  
**CLEANER**



**TURN BACK TIME****THEO TM-300 LASER CLEANER**

Experience the power of the THEO TM-300 handheld laser cleaner, designed to effectively remove rust, paint, and contaminants from surfaces, restoring them to their original condition—it's almost as if you could turn back time.

Engineered and manufactured by Maxphotonics, the world's leading fiber laser expert, the THEO TM-300 is tailored for small to medium-sized businesses, delivering high-quality, affordable, and safe laser cleaning across a wide range of industries.

**KEY FEATURES**

- Safe and Reliable Cleaning
- Powerful 300W Pulsed Laser
- Multiple Beam Patterns
- Cost-Effective Operation
- Fast Cleaning Performance
- Intuitive Cleaning Head Controls
- Intuitive 10.4" Display Interface
- Portable and Ergonomic Design
- Air-Cooled for Mobility
- Industrial-Grade Durability

**TECHNICAL SPECIFICATION**

**Laser Power:** 300W (Pulsed)

**Cooling Method:** Air-cooled

**Scan Speed:** Up to 8m/s

**Display:** 10.4" Touch Interface / 1.8" Handle Screen

**Safety Features:** Human Detection, Fiber Breakage Detection, Distance Meter, Dual-Trigger and Smart Interlocks (PL-d certified)

**Weight:** Approx. 120lbs / 55kg  
(including portable trolley)

**Weight of Cleaning Head:** ~6.6lb / 3kg

**Fiber Length:** 5m (optional 15m)

**Wavelength:** 1064nm

**Power Supply:** 1P + PE | 240V | 50-60Hz

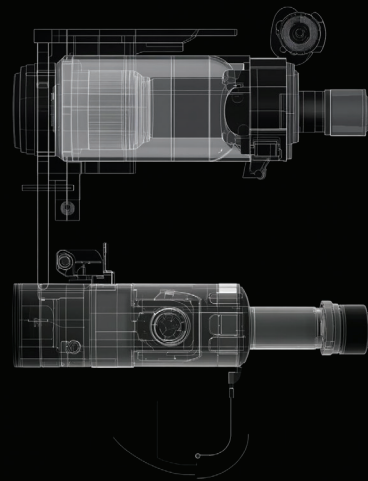

Industrial design pending.

**LASER CLEANING ADVANTAGES**

Traditional methods like chemical cleaning, abrasive blasting, or manual scraping come with limitations, high costs, and environmental hazards. The THEO TM-300 addresses these issues with precision, speed, and a non-contact approach.

**GET IN TOUCH**

**Phone :** +1 (508) 299 5640 | **Email :** hello@theo.inc

**Address :** THEO LASER Inc, 1900 W. Park Dr., Suite #150, Westborough, MA 01581, USA

BY **MAX** PHOTONICS



[www.theo.inc](http://www.theo.inc)